

**10" PRV STATION PLAN**  
N.T.S.

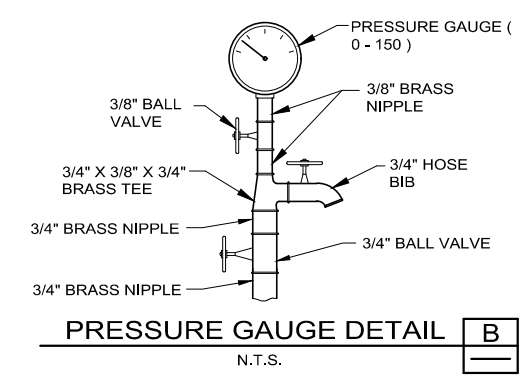

**PRESSURE GAUGE DETAIL B**  
N.T.S.

PRESSURE REDUCING STATION VALVE AND FITTING SCHEDULE			
NO.	DESCRIPTION	SIZE	JOINT
1.	REDUCER WITH MEGALUG RESTRAINT ON INFLOW SIDE	12" X 10"	MJ
2.	DUCTILE IRON PIPE	10"	-
3.	FLANGE COUPLING ADAPTER	10"	FLG X PE
4.	WALL PIECE WITH THRUST RING	10" X 2'-0"	FLG
5.	CROSS W/ 3/4" TAP	10" X 4"	FLG
6.	GATE VALVE (SEE TABLE NOTES)	10"	FLG
7.	NIPPLE	10"	FLG
8.	PRESSURE REDUCING VALVE (CLA-VAL 90-01)	10"	FLG
9.	SPOOL PIECE	10" X 1'-0"	FLG X PE
10.	TEE WITH 3/4" TAP	10" X 4"	FLG
11.	REDUCER	4" X 3"	FLG
12.	90° ELBOW	3"	FLG
13.	GATE VALVE (SEE TABLE NOTES)	3"	FLG
14.	PRESSURE REDUCING VALVE (CLA-VAL 90-01)	3"	FLG
15.	FLANGE COUPLING ADAPTER	3"	FLG X PE
16.	NIPPLE	3"	FLG X PE
17.	PRESSURE RELIEF VALVE (CLA-VAL 50-01)	3"	FLG
18.	COMPANION FLANGE	3"	FLG X THD
19.	GALVANIZED IRON PIPE	3"	THD
20.	PIPE SUPPORT (GRINNELL NO. 264 - 4 REQUIRED)	-	-
21.	FLOOR DRAIN	6" X 2"	-

TABLE NOTES: UNLESS OTHERWISE SPECIFIED, ALL PIPE AND FITTINGS ARE DIP CLASS 53. ALL FLANGES ARE ANSI CLASS 125. PROVIDE MEGALUG RESTRAINT ON ALL MJ FITTINGS. PROVIDE BRONZE OR STAINLESS STEEL BOLTS FOR ALL CONNECTIONS WITHIN VAULT. MUELLER RESILIENT SEAT, CLOW RESILIENT WEDGE OR EAST JORDAN GATE VALVE.

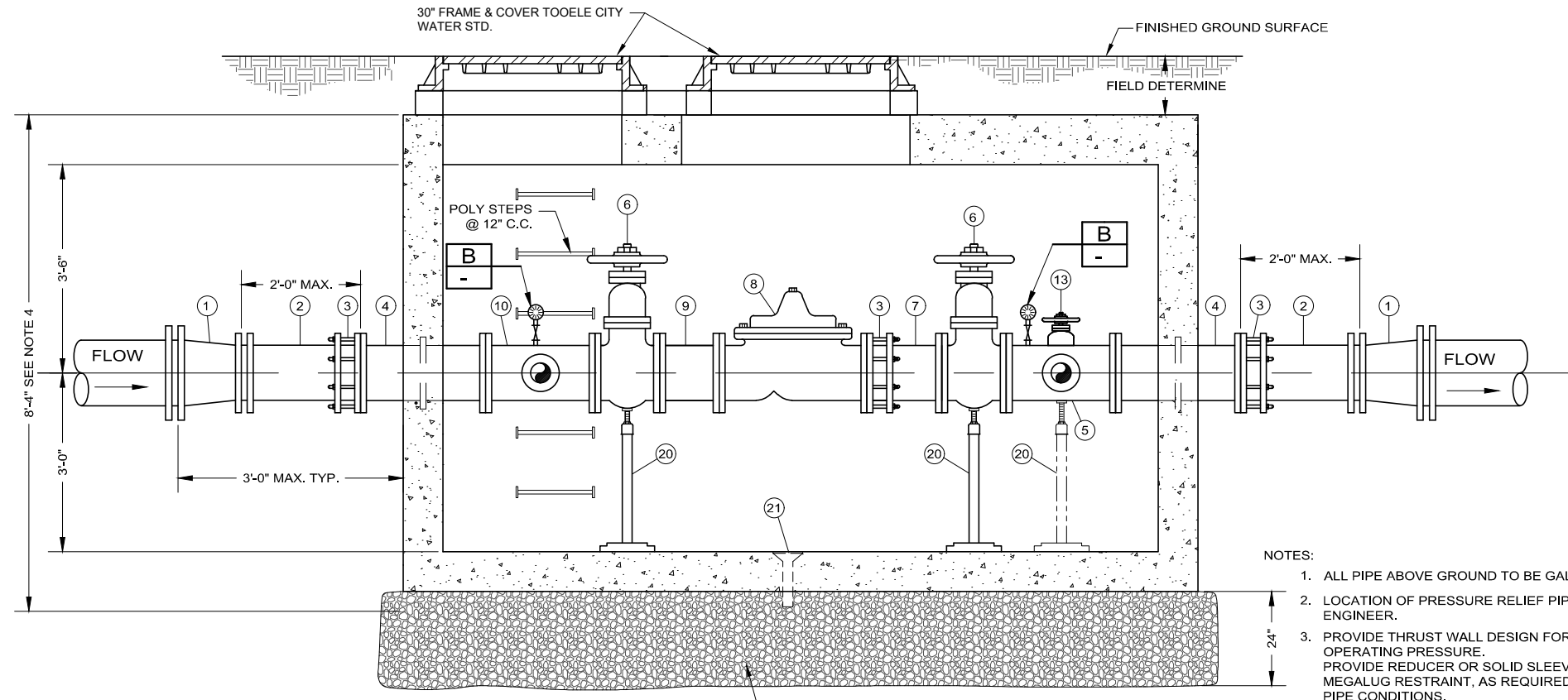

**SECTION 1**  
N.T.S.

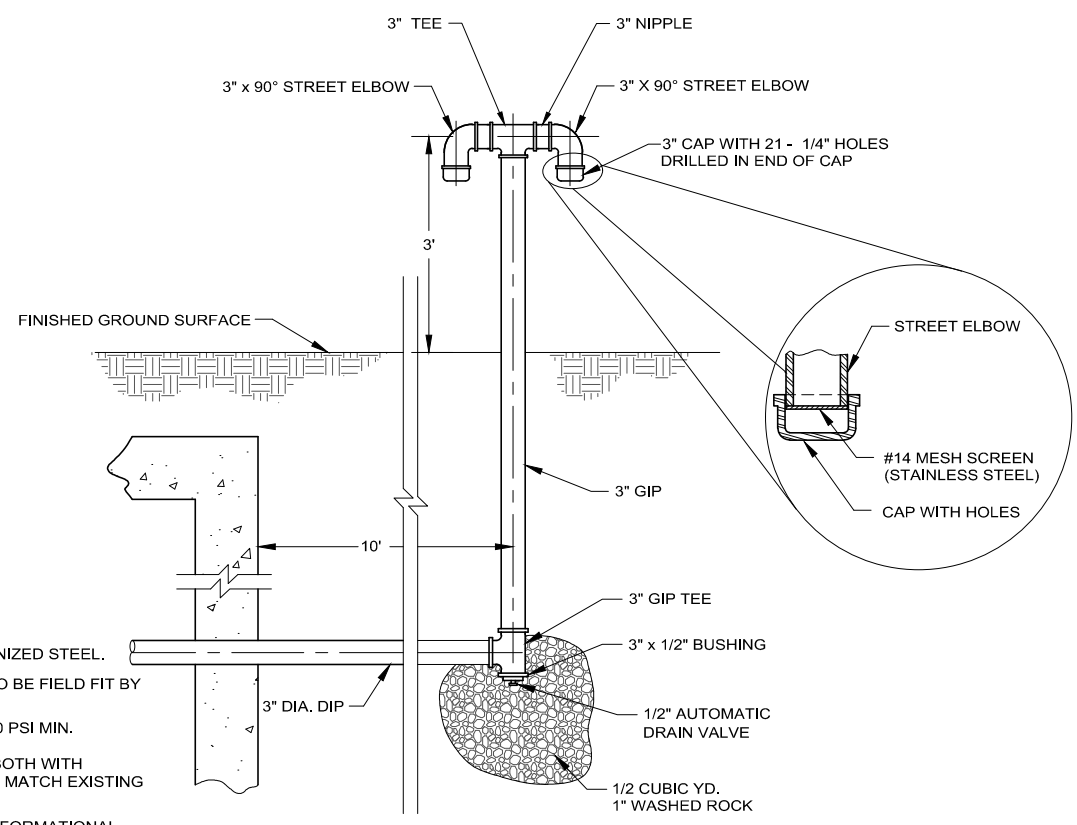

**PRESSURE RELIEF PIPE A**  
N.T.S.

- NOTES:
1. ALL PIPE ABOVE GROUND TO BE GALVANIZED STEEL.
  2. LOCATION OF PRESSURE RELIEF PIPE TO BE FIELD FIT BY ENGINEER.
  3. PROVIDE THRUST WALL DESIGN FOR 150 PSI MIN. OPERATING PRESSURE. PROVIDE REDUCER OR SOLID SLEEVE, BOTH WITH MEGALUG RESTRAINT, AS REQUIRED TO MATCH EXISTING PIPE CONDITIONS.
  4. VAULT DIMENSIONS SHOWN ARE FOR INFORMATIONAL PURPOSES ONLY. H-20 MIN. LOADING REQUIRED. PROVIDE SHOP DRAWINGS FOR ENGINEERS APPROVAL PRIOR TO CONSTRUCTION.



**10" PRESSURE REDUCING VALVE WITH 3" BYPASS**